



Akva Vita

Instantaneous water heater for one-family houses and flats

Instantaneous water heater with heat exchanger. Supplied directly from district heating network. Designed for wall-mounting.

Application

The Akva Vita is an instantaneous water heater featuring high performance and simple operation. The Akva Vita fulfils the domestic hot water requirement for a one-family house of 35 kW at a flow temperature of 70°C. Consequently, the Akva Vita is very suitable for central or individual heating – as well as in district heating networks, where summer operation at low temperature is to be implemented.

Domestic hot water (DHW)

The domestic hot water is prepared in the heat exchanger based on the flow principle. Supreme ease of operation is obtained via hydraulic control of domestic hot water through a proportional valve – the PM controller, thereby guaranteeing a constant domestic water temperature at all times.

The use of hydraulic control largely prevents the formation of limestone and bacteria due to the fact, that the valve closes immediately when tapping is ended. A thermostatic bypass enables tapping of hot water without any delay, – ensuring the best possible efficiency and economy.

Domestic hot water circulation

The Akva Vita is equipped with bypass function as a standard, and it is prepared for DHW circulation. Switching to DHW circulation is possible from a construction viewpoint, requiring no extra components.

Options

The water heater can be supplied with non-return valve and safety valve mounted in the cold water supply.

Construction

All pipes are made of stainless steel.

The connections are made by nuts and gaskets. The Akva Vita can be delivered with either brushed or white-lacquered stainless steel cover.

FEATURES AND BENEFITS

- Instantaneous water heater
- DHW heating based on the flow principle
- Capacity: 35 kW on DHW
- DHW in sufficient quantity
- Space-saving
- Pipes and plate heat exchanger made of stainless steel
- Minimized risk of limestone and bacteria formation

Akva Vita

Circuit diagram - example

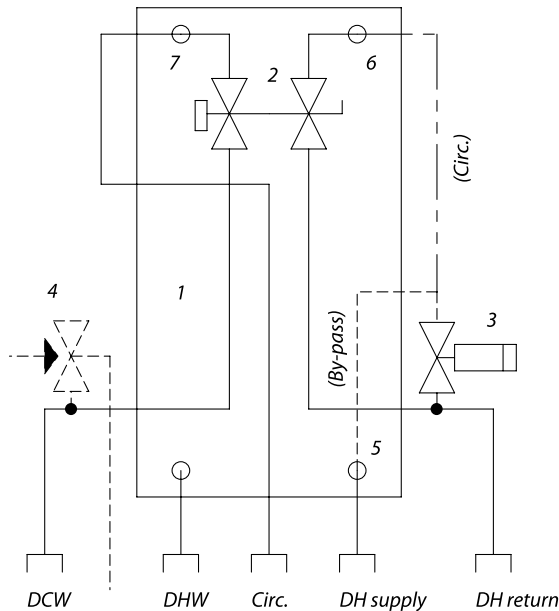

1. Stainless steel heat exchanger AISI 316
2. PM controller
3. Thermostat for by-pass/circulation
4. Safety valve and non-return valve (optional)
5. By-pass connection (for by-pass operation)
6. By-pass connection (if circulation)
7. Blank plate (remove if circulation)

Technical parameters:

Nominal pressure: PN 16
 DH differential pressure: $\Delta p_{\min} = 0.2 \text{ bar}$
 DH supply temperature: $T_{\max} = 120^\circ\text{C}^*$
 DCW static pressure: $p_{\min} = 2,5 \text{ bar}$
 Chloride compounds: Max. 300 mg/l
 *At DH supply temp. above 90°C it is recommended to order the Akva Vita equipped with an additional thermostatic controller.

Weight incl. cover: 10,5 kg (incl. packing)

Cover: Brushed or white-lacquered stainless steel

Dimensions (mm):

Without cover: H 420 x W 250 x D 155
 With cover: H 420 x W 255 x D 160

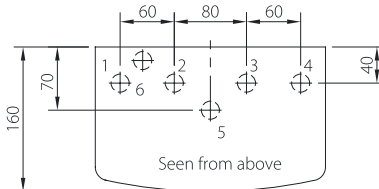

Connections:

1. Domestic cold water (DCW)
2. Domestic hot water (DHW)
3. District heating (DH) supply
4. District heating (DH) return
5. Circulation
6. Blow-off pipe from safety valve - optional

Connections sizes:

DH + DCW + DHW: $R\frac{1}{2}"$ (ext. thread)
 Circulation: $R\frac{1}{2}"$ (ext. thread)

Options:

- Without cover
- With safety valve and non-return valve (DCW)
- With additional thermostatic controller

DHW: Capacity examples, $10^\circ\text{C} / 50^\circ\text{C}$

DHW Capacity kW	Supply flow Primary $^\circ\text{C}$	Return flow Primary $^\circ\text{C}$	DHW Tap load l/min	Pressure loss Primary *bar	Flow rate Primary l/h
35	60	35	12,5	0,39	1220
35	70	28	12,5	0,14	724
35	80	24	12,5	0,08	540
35	90	21	12,5	0,05	436

* heat meter not incl.

Danfoss Redan A/S · District Heating Controls · Sindalsvej 33-35 · DK-8240 Risskov · Denmark
 Phone: +45 87 43 89 43 · Fax: +45 87 43 89 44 · redan@danfoss.com · www.redan.danfoss.dk

Danfoss can accept no responsibility for possible errors in catalogues, brochures and other printed material. Danfoss reserves the right to alter its products without notice. This also applies to products already on order provided that such alterations can be made without substantial changes being necessary in specifications already agreed. All trademarks in this material are property of the respective companies. Danfoss and the Danfoss logotype are trademarks of Danfoss A/S. All rights reserved.