



Akva Lux

Instantaneous water heater for large one-family houses and apartments as well as small apartment houses

Thermostatic and pressure controlled instantaneous water heater with heat exchanger. Supplied directly from district heating network. Designed for wall-mounting.

Application

The Akva Lux is an instantaneous water heater featuring high performance and simple operation. The Akva Lux is especially suitable for large villas with for instance several bathrooms or jacuzzi and for the large family, for which an exceptionally large amount of water is required. The Akva Lux is also very suitable for small apartment houses. The water heater is available in two variants, either for 1-2 apartments or for 3-4 apartments. Consequently, the Akva Lux is very suitable for central or individual heating – as well as in district heating networks, where summer operation at low temperature is to be implemented.

Domestic hot water (DHW)

The domestic hot water is prepared in the heat exchanger based on the flow principle. Supreme ease of operation is obtained via the combined hydraulic and thermostatic regulation of domestic hot

water through the PT°C controller, thereby guaranteeing a constant domestic water temperature at all times. The use of hydraulic regulation largely prevents the formation of lime scale and bacteria due to the fact, that the valve closes immediately when tapping is ended. A thermostatic by-pass enables tapping of hot water without any delay – ensuring the best possible efficiency and economy.

Domestic hot water circulation

The Akva Lux is equipped with by-pass function as a standard and is prepared for DHW circulation. Switching to DHW circulation is possible from a constructional point of view, requiring no extra components.

Options

The water heater can be supplied with non-return valve and safety valve mounted in the cold water supply.

Construction

All pipes are made of stainless steel. The connections are made by nuts and gaskets. The Akva Lux is delivered with anthracite grey-lacquered frame with a slightly curved brushed stainless steel cover.

FEATURES AND BENEFITS

- Instantaneous water heater
- DHW heating based on the flow principle
- Capacity: 41 - 53 kW on DHW
- DHW in sufficient quantity
- Space-saving
- Pipes and plate heat exchanger made of stainless steel
- Minimized risk of lime scale and bacteria formation

Akva Lux

Circuit diagram

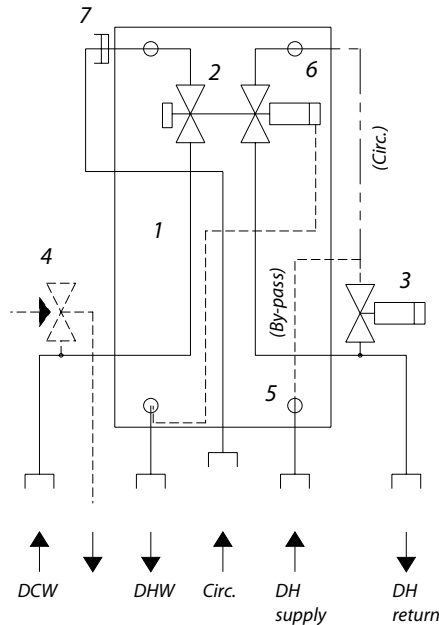

1. Plate heat exchanger DHW
2. PTC controller
3. Thermostat for by-pass/circulation
4. Safety valve and non-return valve (optional)
5. By-pass connection (for by-pass operation)
6. By-pass connection (if circulation)
7. Blind plate (remove if circulation)

Technical parameters:

Nominal pressure: PN 16
 DH supply temperature: $T_{max} = 90^{\circ}C$
 DCW static pressure: $p_{min} = 2,5 \text{ bar}$
 Chloride compounds: Max. 300 mg/l

Weight incl. cover: 15,0 kg
 (incl. packing)

Cover: Brushed stainless steel

Dimensions (mm):

Without cover: H 463 x W 270 x D 180
 With cover: H 463 x W 305 x D 200

Connections:

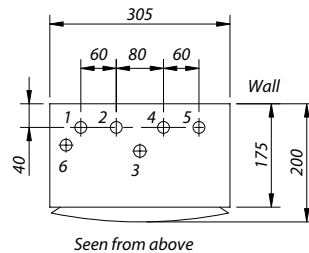

- 1 Domestic cold water (DCW)
- 2 Domestic hot water (DHW)
- 3 Circulation
- 4 District heating (DH) supply
- 5 District heating (DH) return
- 6 Blow-off pipe from safety valve - optional

Connections sizes:

DH + DCW + DHW: G 3/4" (ext. thread)
 Circulation: R 1/2" (ext. thread)

Options:

- Without cover
- With safety valve and non-return valve (DCW)

DHW: Capacity examples, 10°C / 50°C

DHW Capacity kW	Supply flow Primary °C	Return flow Primary °C	DHW Tap load l/min	Pressure loss Primary *bar	Flow rate Primary l/h
41	60	26	14,7	0,59	1030
41	70	20	14,7	0,28	706
41	80	17	14,7	0,18	562
41	90	15	14,7	0,13	472
53	60	24	19,0	0,68	1256
53	70	18	19,0	0,34	882
53	80	16	19,0	0,22	709
53	90	14	19,0	0,16	601

* w/o heat meter

Danfoss Redan A/S · District Heating Controls · Sindalsvej 33-35 · DK-8240 Risskov · Denmark

Phone: +45 87 43 89 43 · Fax: +45 87 43 89 44 · redan@danfoss.com · www.redan.danfoss.dk

Danfoss can accept no responsibility for possible errors in catalogues, brochures and other printed material. Danfoss reserves the right to alter its products without notice. This also applies to products already on order provided that such alterations can be made without substantial changes being necessary in specifications already agreed. All trademarks in this material are property of the respective companies. Danfoss and the Danfoss logotype are trademarks of Danfoss A/S. All rights reserved.